



schmidt
a brand of aebi schmidt

MFH 550

Sweeper



The MFH 550 is ideal for daily cleaning jobs in inner city areas, on footpaths and cycle paths and in industrial areas. Due to its high suction power, the MFH 550 sweeps at a high working speed and easily picks up large amounts of dirt. The large volume of the sweeping hopper allows maximum sweeping capacity and a long service life. The MFH 550 is characterised by environmentally friendly engine technology, innovative engineering, low costs over the product life cycle and maximum comfort for the driver.

Highlights

- A **2 or 3-brush system** with a pulled suction chute.
- Container available with **tilting or high discharge**
- System volume of 5m³ integrated in vehicle in compact design
- Efficient, quiet running **Euro 6c six-cylinder diesel engine**
- High payload of up to **6,600 kg**

Your benefits

- **Powerful:** Sweeps at a fast working speed due to the high suction power and easily picks up large amounts of dirt. Thanks to the largest payload in its class, full utilisation of the container volume is possible even with heavy swept material.
- **Unsurpassed comfort:** A spacious cabin, excellent visibility, ergonomic controls, an adjustable steering column, and a sprung driver's seat with individual adjustment options. AGR („Healthy back campaign“) tested and recommended.
- **Minimum fine dust emissions:** The MFH 550 meets the best level of PM10/PM2.5 certification with four stars each. The combination of the Koanda air circulation system and the pressurised circulating water system can reduce fine dust emissions by up to 70%.
- **Flexibility:** Modular equipment and a wide range of optional expansion possibilities means the sweeper can be adapted to customer-specific requirements.

Performance features

Sweeping technology

The MFH 550 has a pulled disc brush system mounted in front of the front axle with a sweeping width of 2,200mm. The advantage of the trailed design is that collision damage is minimised compared to the pushed system and wear and tear on the brushes is significantly reduced.

The MFH 550 is available as a two- or three-blade system. With the optional third brush, the working width can be increased to 3,550mm. This allows a greater area performance of up to 64,000m²/h, sweeping on two levels and efficient sweeping in areas with a lot of street furniture and tight working areas. The robustly designed arm with front brush can be used on both the left and right side of the machine and is also suitable for heavy weed work.

All functions of the MFH 550 can be controlled hydraulically from the control panel in the driver's cab. The entire sweeping unit can be moved hydraulically 300mm to the right and left. With optional independent brush control, the inclination of the circular brushes can be adjusted hydraulically from the cab to suit the road surface characteristics. The contact pressure of the disc brushes can be adjusted separately to the right and left from the cab. This allows comfortable and clean sweeping of right-angled corners, gutters and hard-to-reach areas.

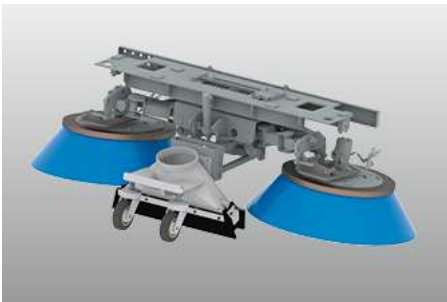

Suction and water systems

The trailed suction shaft is located behind the brushes but in front of the front axle and is carried along on rollers at a constant distance from the floor. The suction mouth and the circular brushes form one unit - the parallelogram suspension of the brush unit guarantees optimum tracking and thus overlap with the suction shaft. The flow-optimised installation of the suction shaft ensures that sweeping can be carried out effectively and with reduced fuel consumption even at low blower speed. A hydraulically operated coarse dirt flap allows large debris to be collected. The blower speed can be easily and conveniently adjusted with almost infinite variations, which allows quick reaction to changing conditions.

The fresh water system has a volume of around 685 litres, and optionally up to 1835 litres. The powerful water pump supplies two spray nozzles each on the circular brushes and two nozzles in the suction shaft.

As an option, the MFH 550 can also be equipped with a circulating water system. In this case, the circulating water from the hopper is fed directly back into the suction shaft, saving fresh water and optimising use of the container capacity. The collected waste material is both moistened and compressed, and only clean, low-dust air is released into the environment.

The MFH 550 is certified with the best level PM10 and PM2.5 certificate, which is highly regarded throughout Europe and awards four stars in both the PM10 test for the highest level of air pollution control and the best possible absorption performance with PM2.5.

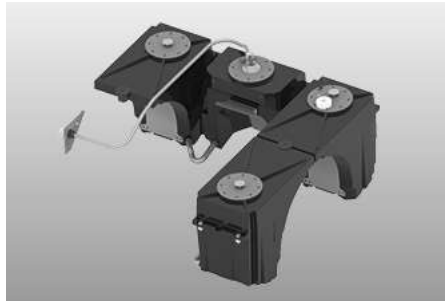
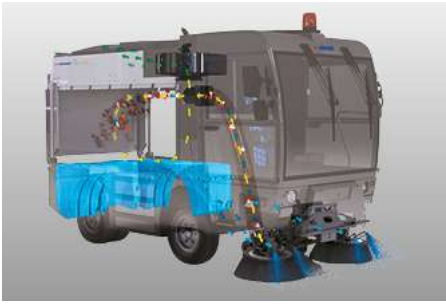

Sweeping material container

The 5m³ volume hopper enables maximum sweeping capacity and an increased radius of action. The basic version is equipped with tipping discharge. A high dump with pusher for container emptying is optionally available. The hydraulically locked tailgate with a stable rubber seal ensures the tailgate to the container is watertight. The frame of the container is made of a stable steel construction which is subjected to wet painting. The bottom and sides of the container are lined with aluminium or stainless steel plates as required. Alternatively, the MFH 550 is available with a stainless steel frame.

A leaf sieve is fixed over the entire width and length of the hopper and allows the hopper capacity to be used to its full potential. The large sieve surface prevents the sieve from clogging and guarantees a constant air flow with 100% container filling. The sieve can be conveniently folded down for cleaning. Automatic leaf screen cleaning for the front screen section is available as an option.



Ergonomics & Comfort

When designing the cabin, the focus was on ease of operation and ergonomics. Best visibility is through a spacious cab with windscreen that extends to the cab floor, while a window in the floor provides a clear view of the suction shaft and the disc brushes. Two large side mirrors also provide a perfect view of the working area and surroundings. The cab is equipped with high-quality noise and vibration insulation. At only 66 dB(A), the driver can concentrate better and perform tasks quickly and safely.

All control and operating elements are arranged around the driver's seat with AGR certificate („Campaign for healthier backs“) and are within easy reach. A powerful heating and air conditioning system ensures the best possible indoor climate during work. A narrow and multi-adjustable steering column is equipped with all traffic and safety-related functions and controls. The ergonomically designed transition between the accelerator and brake pedals, low pedal forces and cruise control make the driver's work easier.

The sweeping unit is controlled via the door control panel with joysticks and push buttons. The most important information is visible at first glance on the colour display in the roof console. For example, travel speed, fill levels, temperatures, engine speed and working conditions are all displayed. The Auto-Drive option is new. All sweeping functions and driving commands in sweeping mode can be conveniently operated via the ergonomically shaped multi-functional joystick. A mechanic can make machine-specific settings via the display. The onboard diagnosis system allows any faults to be located quickly and efficiently.



Modern vehicle technology

The frame of the MFH 550 is made of high-strength steel and is primed and painted in high-quality processes. This forms an effective corrosion protection and guarantees sustainable use in all weather conditions. The ladder frame construction makes the MFH 550 light and at the same time robust and reliable. C-profiles ensure maximum stability and torsional rigidity. The hydraulic tank is also made of robust steel, while the side and rear water tanks are constructed of stable, impact-resistant plastic.

The suspension package with leaf springs and hydraulic shock absorbers at the front and rear, adapted to the machine, ensures safe and comfortable driving. Large 17.5" wheels with high load capacity ensure increased safety when driving even in bad road and weather conditions. The MFH 550 has the highest payload in its class - up to 6,600 kg thanks to robust suspension, high axle loads and twin tyres on the rear axle.

A large steering angle of 68°, combined with the short wheelbase of 1,850 mm, allows optimum manoeuvrability and an extremely tight turning circle.

The hydraulic dual-circuit brake system, with disc brakes at the front and drum brake system at the rear, and the optional or equipment-dependent automatic load-dependent brake valve on the rear axle, provides outstanding vehicle control.

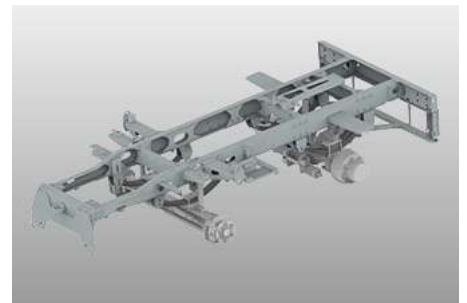

Drive

The MFH 550 is equipped with an efficient and powerful Euro 6c diesel engine with the most advanced exhaust aftertreatment system available on the market, with diesel oxidation catalyst, closed particle filter system, AdBlue injection and SCR catalyst. The smooth and powerful six-cylinder engine, in conjunction with the newly designed hydrostatic drive with Eco-Drive, ensures comfortable and economical driving. The speed reduction during transport trips saves up to 20% diesel fuel. Optional transport speeds 25/40/45/50 km/h (15/25/28/31mph). The engine, including AdBlue tank, is perfectly integrated into the chassis, so that the MFH 550 maintains optimum manoeuvrability.



Wide range of options

- Third front brush
- Wild herb brush
- Rear view and suction shaft camera
- Pressure washer
- Roof boom with HD lance
- Additional water tank
- Hand suction hose
- Automatic central lubrication system
- Sound insulation package
- LED lighting package
- Winter maintenance options: Snow plough or front brush



IntelliOPS telematics platform

If you want to monitor, plan, control in real time, optimise or, for example, bill third parties for the activities of your MFH 550, then use the digital solutions on our IntelliOPS platform. IntelliOPS supports you in the efficient use of your individual machine as well as in a network with several machines, including those of other brands. Here you can find out more about our digital solutions and how you can use them in a way that is modular and adapted to your needs.

Variants

MFH 550 | 2 brush system



A flexible sweeping system guarantees a clean result in every situation. The pulled disc brush system mounted in front of the front axle has a sweeping width of 2,200 mm.

MFH 550 | 3 brush system



With the optional third brush, the working width can be increased to 3,550 mm. This allows a greater area output and sweeping on two levels.

Related products

eSwingo 200+

Sweeper



Swingo 200+

Sweeper



Flexigo 150

Sweeper



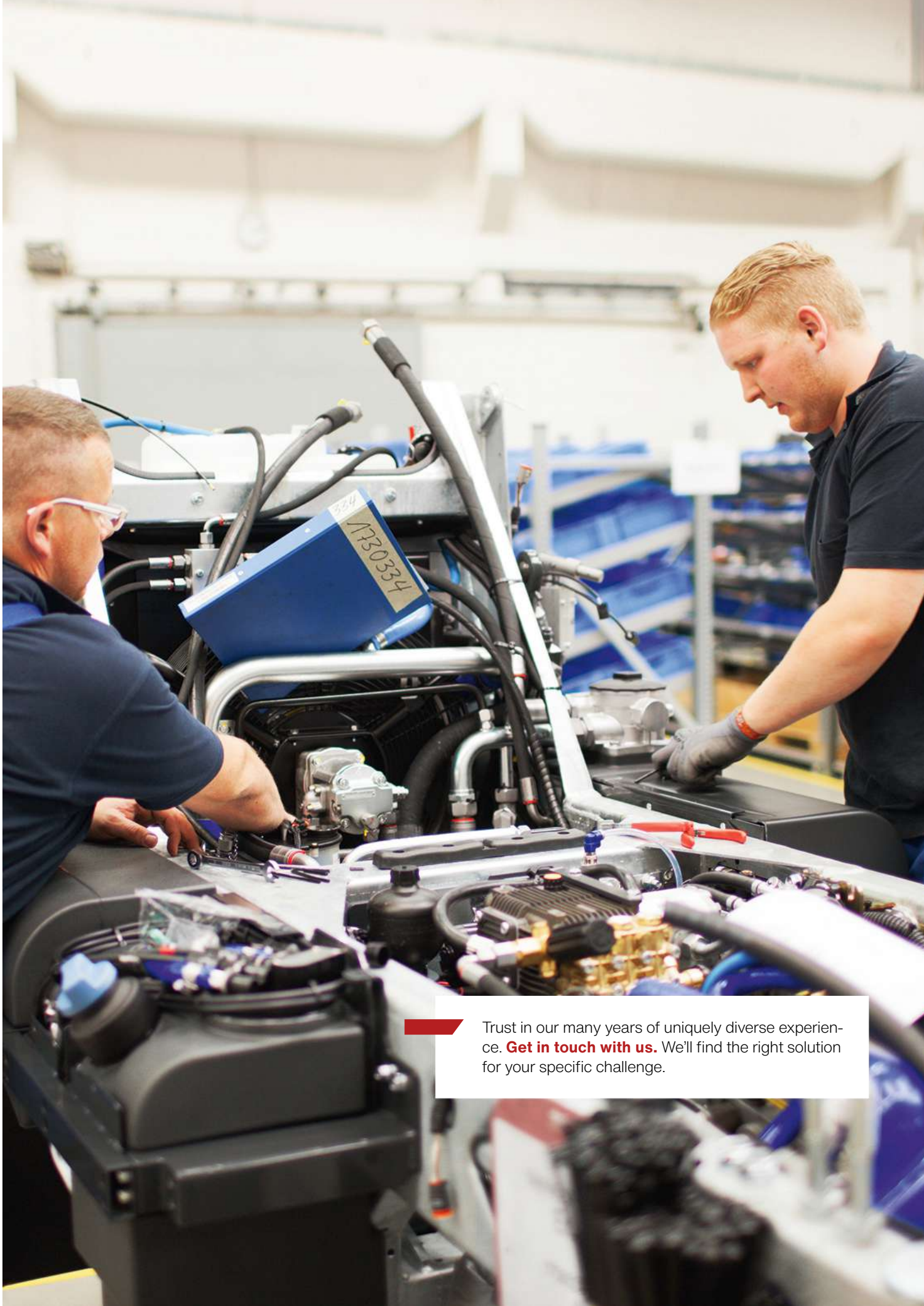

Trust in our many years of uniquely diverse experience. **Get in touch with us.** We'll find the right solution for your specific challenge.

Technical data

	MFH 550 2 brush system	MFH 550 3 brush system
Hopper		
Hopper volume	5 m ³	5 m ³
Tilt angle	55°	55°
Dumping height tilt discharge	1,100 mm	1,100 mm
Dumping height high discharge	1,100 - 1,820 mm	1,100 - 1,820 mm
Sweeping unit		
Disc brush diameter	900 mm	900 mm
Disc brush speed	140 1/min	140 1/min
Brush material	Steel / Plastic / Mixfill	Steel / Plastic / Mixfill
Sweeping width	2,200 mm	2,200 mm
Sweeping width with 3rd brush	-	3,550 mm
Suction fan		
Max. air flow rate (free flow)	14,000 m ³ /h	14,000 m ³ /h
Max. approx. vacuum	850 mm	850 mm
Speed	3,400 1/min	3,400 1/min
Water system		
Total water volume	685 l	685 l
Fresh water pump	3.4 bar / 15 l/min	3.4 bar / 15 l/min
Water tank material	PE polyethylen	PE polyethylen
Drive system - auxiliary engine 2		
Engine type	FCA R756	FCA R756
Number of cylinders	6	6
Exhaust emission	Euro 6c	Euro 6c
After treatment system	AdBlue + SCR-Kat	AdBlue + SCR-Kat
Fuel	Diesel	Diesel
Displacement	4,455 cm ³	4,455 cm ³
Performance	120 kW (163 HP)	120 kW (163 HP)
Torque	500 Nm	500 Nm
Fuel tank	110 l	110 l
AdBlue tank	14 l	14 l
Steering		
Steering angle front axle	68°	68°
Ø Turning circle wall/wall	7,250 mm	8,100 mm
Ø Turning circle kerb/kerb	5,950 mm	5,950 mm
Speed		
Sweeping speed permanent use	12 / 18 km/h	12 / 18 km/h
Dimensions		
Length without 3rd brush	4,450 mm	4,450 mm
Length with 3rd brush	-	5,487 mm
Width without brush	1,810 mm	1,810 mm
Height with beacon	2,707 mm	2,707 mm
Wheelbase	1,850 mm	1,850 mm
Track width front	1,600 mm	1,600 mm
Track width rear	1,310 mm	1,310 mm
Weights		
Empty weight of the basic unit approx.	5,500 kg	5,500 kg
Permitted total weight	12,100 kg (40 km/h) 11,500 kg (50 km/h)	12,100 kg (40 km/h) 11,500 kg (50 km/h)

