



schmidt
a brand of aebi schmidt

Street King 660

Sweeper



The Street King 660 is an especially powerful and efficient truck-mounted sweeper. It boasts outstanding suction power, a large 7m³ hopper, and a high water volume for long sweeping distances and maximum efficiency. With a self-supporting frame, the mounted sweeper can be attached to any truck type, provided that its load capacity conditions continue to be satisfied for approval – a unique concept that offers maximum flexibility and adaptability.

Highlights

- **Intuitive and convenient operation** by a 7" colour touch screen and door control panel with joystick.
- **Roller brush** integrated in the suction shaft enables a **higher sweeping speed of 15%**.
- **Low centre of gravity** and safe handling.
- Most modern and **resource-saving engine technology**.
- With the **kit solution**, the sweeper can easily be mounted on a defined truck in the country of destination.

Your benefits

- **Excellent sweeping performance:** A right or left mounted sweeping unit in towed design, a suction shaft with integrated roller brush and pneumatically operated debris flap ensure efficient collection of debris.
- **Long sweeping operations:** The generously dimensioned water tanks and the pressurized circulating water system extend the operating time by up to 30%.
- **Best certification:** The Street King 660 meets the best level of PM10/PM2.5 certification with four stars each.

Performance features

Sweeping technology

A towed sweeping unit mounted on either the right or left with brake-back protection ensures direct and efficient collection of debris. The roller brush, which is optimally integrated into the suction shaft, enables **a higher sweeping speed of 15%** without impairing the sweeping result. A pneumatically operated coarse dirt cover is also provided for easy collection of larger debris. In the dual version, the machine can easily guarantee a sweeping width of 3,500mm with the simultaneous sweeping option.



- Outstanding sweeping results even when cornering, thanks to excellent coverage with disc brush, roller brush and suction shaft
- Minimal brush wear thanks to adjustable brush contact pressure and speed
- Separate, continuously adjustable gutter channel brush speeds and feed brush roller speeds (optional)
- Automatic sweeping unit raising and water pump shut-off when reversing
- An optional dual design with a sweeping width of 3,500mm – simultaneous sweeping
- No maintenance or lubrication work (no lubrication points required)

Suction system

The suction fans installed are transverse to the direction of travel in the front part of the hopper. This significantly reduces the overall length and enables an optimised air flow. Due to the low air resistance, a maximum suction capacity of 18,000 m³/h is achieved.



Water system

Generously proportioned water tanks with a volume of 1,600 litres help to ensure long sweeping distances. Mounting the water tank at the rear helps to ensure a lower centre of gravity for better road handling. And, by not joining the water tanks to the hopper, we have achieved greater stability during tipping. Additional water tanks can be mounted between the driver's cabin and the sweeping system to provide with up to 1,000 litres of additional capacity. At the same time, the auxiliary water tanks ensure noise reduction between the auxiliary engine and the driver's cab.



A particular highlight is the optional water volume control, which is accessible on the ES control panel and allows the water volume to be adjusted in three stages. Individual water jets can be activated and deactivated by touch command, helping to reduce water consumption considerably, extend sweeping times and conserve resources. All of these functions are accomplished without the need to route the water lines through the truck's cabin.

The optional innovative pressurised water recirculation system can extend usage times by up to 30%. Waste water is channelled into the suction shaft using a separate waste water pump at the rear of the water tank, then sucked up again and re-treated. This helps to reduce the need for time-consuming water refills, reduce emissions of fine dust and particulate through better dust binding and keep the suction pipe permanently flushed to minimise blockages.

Sweeping material hopper



The large 7.0m³ hopper allows for the collection of large quantities of debris. The floor pan made from stainless steel and the rubberised baffle plates inside the hopper combine to ensure a lengthy service life and virtually no wear.

The fully integrated unit compartment for the hydraulic, pneumatic and electrical systems ensures quick and easy maintenance, with everything accessible from the outside through large covers. The baffle plates also act as sound proofing. The large tipping angle of 60° allows the hopper to be emptied fully, leaving no residue behind. A large, folding leaf screen is fitted over the entire width of the hopper.

The aerodynamic shape of the hopper, air flow and leaf screen produce a cyclonic effect inside the hopper to ensure maximum capacity utilisation and fewer emptying runs. An inspection cover on the side allows for additional inspection of the fill level inside the hopper.



Ergonomics and comfort

Logical and intuitive menu navigation and automatically controlled processes help to support drivers when working by ensuring that concentration remains focused on the road ahead.

- Operating technology with a 7" colour touch screen
- Door control panel with joystick for basic functions
- Main functions can be controlled with one hand using the door control panel
- Audible and visual warning notifications
- Automatic display brightness adjustment (light sensor)
- On-board diagnostics
- Optional TFT monitor for up to three cameras



The ideal drive concept

With the one- and two-engine variants, the Street King 660 offers consistent performance and maximum flexibility regardless of the drive concept. There is a choice between two drive variants - **motor driven or hydrostatic drive** - which means the customer's wishes can be individually catered for.

1. Motor driven

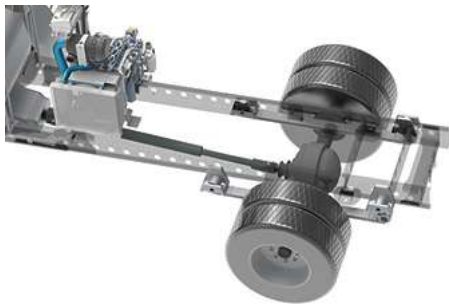

2. Hydrostatic drive



Full power without superstructure motor

The hydrostatic drive concept offers excellent control throughout the entire sweeping operation and allows infinitely variable control of the travel speed between 0 and 25 km/h. A high-resolution, TFT colour display enables easy operation, fast navigation and precise control of the hydrostatic drive with maximum comfort - even during long working operations.

The hydrostatic drive is the ideal drive concept for customers who want to operate without a superstructure engine. The hydrostatic unit is mounted between the transmission output and the rear axle differential. In sweeping mode, the mechanical drive is disconnected and the power flow is directed via the transmission output to the powerful hydraulic pump. This in turn drives the hydraulic motor, which drives the corresponding rear axle. At the same time, the hydrostatic transmission reliably supplies the sweeper body with the necessary power for all driving and sweeping situations.

Suction fan and hydraulic unit drive

The enclosed engine compartment combined with state-of-the-art engine technology has helped to make the Street King 660 one of the quietest and most environmentally friendly sweepers on the market. The auxiliary engine is highly efficient at supplying power and the engine compartment can be accessed with ease when the hopper is tilted.

Vehicle requirements

Standard truck chassis with a total permissible weight of 15 - 18 tonnes and a wheelbase of approx. 3,200 - 3,500 mm, depending on the chassis and engine type. The sweeper is attached to a universal intermediate frame and not to the truck itself, leaving open the opportunity for the sweeper to be configured as a demountable sweeper if required - this allows the truck to be used as a winter maintenance vehicle if required.

Sustainability taken to the streets

The Street King 660 with hydrostatic drive can be mounted on a CNG-powered truck to provide the ideal combination for low emission sweeping operations, while meeting demand for an alternative fuel sweeper. This combination represents an attractively priced, modern and sustainable alternative to diesel power, reducing noise and emissions during sweeping operations at the same time.

Options

1. Wander hose on the rear door or as roof mounted version for cleaning sink holes and sucking up large debris.
2. Surrounding LED lighting for optimum illumination of the sweeping area and machine environment.
3. Spray bar and high-pressure water spray system for moistening the sweeping surface and removing persistent dirt.
4. Rear suction unit for full-surface suction over the entire vehicle width.
5. Exhaust air management for targeted reaction to the conditions, for example, when sweeping under trees.
6. Pressurised recirculating water system (see section on water system).
7. Leaf screen cleaning allows comfortable cleaning of the leaf sieve.



Interchangeable system

In just a few hours, the Street King 660 can be converted from a sweeper to a spreader with snow plough. This means that the same truck can be used for summer and winter maintenance. This not only saves space but also reduces costs.

The quick-change system enables the conversion to be carried out in just a few steps and with maximum precision. Especially as the mounting elements are easy to reach and the changing platform can be conveniently pushed in and out.



Hopper level sensor

The effective hopper level in a sweeper hopper can only be determined to a limited degree with the current state of the art. The axle load sensors can only determine when the axle load has been reached, without being able to provide information about the actual hopper fill level. This does not take into account the important factor of the density of the swept material. This means that if light debris such as leaves are picked up, the hopper can be overfilled without the axle load sensor reacting. Aebi Schmidt presents a patented sensor system that reliably indicates the current hopper level by means of radar waves. Thus, the operator can see at any time to what percentage the hopper is actually filled. One of the highlights is that the measurement takes place fully automatically parallel to the sweeping operation. The level sensor detects the exact debris level in the hopper with the help of adequate radar technology. The sensor works reliably in all weather conditions and is securely mounted against damage or contamination. A system that saves drivers time, makes work easier and guarantees more flexibility.

IntelliOPS telematics platform

If you want to monitor, plan, control in real time, optimise or, for example, bill third parties for the activities of your Street King 660, then use the digital solutions on our IntelliOPS platform. IntelliOPS supports you in the efficient use of your individual machine as well as in a network with several machines, including those of other brands. Here you can find out more about our digital solutions and how you can use them in a way that is modular and adapted to your needs.

Gallery



Related products

eCleango 550

Sweeper



eSwingo 200+

Sweeper





Trust in our many years of uniquely diverse experience. **Get in touch with us.** We'll find the right solution for your specific challenge.

Technical data

Hopper

Hopper volume	7 m ³
Tilt angle	60°

Sweeping unit

Disc brush diameter	550 / 650 / 750 mm
Brush material	Steel / Mixfill
Sweeping width	2,350 mm
Sweeping width dual version	3,500 mm
Roller brush diameter	400 mm
Roller brush length	1,300 mm

Suction fan

Type of drive	Hydraulic motor
Max. air flow rate (free flow)	18,000 m ³ /h
Speed	2,100 - 3,100 1/min

Water system

Total water volume	1,600 l
Fresh water pump	8 bar / 48 l/min

Drive system - auxiliary engine

Engine type	Deutz TD 2.9 L04
Number of cylinders	4
Exhaust emission	EuroMot V
After treatment system	DOC + DPF
Fuel	Diesel
Displacement	2,900 cm ³
Performance	55.4 kW (75 HP) @ 2,600 1/min
Torque	260 Nm
Speed range	1,600 1/min

Drive system - auxiliary engine 2

Engine type	Deutz TD 2.9 L04
Number of cylinders	4
Exhaust emission	EuroMot IIIA
After treatment system	None
Fuel	Diesel
Displacement	2,900 cm ³
Performance	55.4 kW (75 HP) @ 2,600 1/min
Torque	260 Nm
Speed range	1,600 1/min

Hydraulic system

Hydraulic tank volume	130 l
-----------------------	-------

Speed

Sweeping speed permanent use	20 km/h
------------------------------	---------

Weights

Empty weight of the basic unit approx.	4,250 kg
Weight of the dual version approx.	4,650 kg